

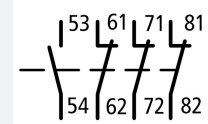

Auxiliary contact, 1N/O+3N/C, surface mounting, spring clamp connection

Part no. 13DILE-C
Article no. 230259
Catalog No. XTMCXFAC13

Delivery program

Product range			Accessories
Accessories			Auxiliary contact modules
Description			with interlocked opposing contacts
Function			for standard applications
Number of poles			4 pole
Connection technique			Spring-loaded terminals
Rated operational current			
AC-15			
220 V 230 V 240 V	I_e	A	4
380 V 400 V 415 V	I_e	A	2
Contacts			
N/O = Normally open			1 N/O
N/C = Normally closed			3 NC
Mounting type			Front fixing
Contact sequence			
For use with			DILE(E)M-10-C(-G)(...) DILE(E)M-01-C(-G)(...) DILER40(-G)-C DILER31(-G)-C DILER22-C
Instructions			No interlocked opposing mechanism in NO early-makes and NC late-breaks. Auxiliary contact modules with positive acting contacts
Code number and version of combination			
Distinctive number			53E
			44
			35

Technical data

Auxiliary contacts

flexible with ferrule			Yes
Rated impulse withstand voltage	U_{imp}	V AC	6000
Overvoltage category/pollution degree			III/3
Rated insulation voltage	U_i	V AC	690
Rated operational voltage	U_e	V AC	600
Safe isolation to EN 61140			
between coil and auxiliary contacts		V AC	300
between the auxiliary contacts		V AC	300
Rated operational current		A	
Conventional free air thermal current, 3 pole, 50 - 60 Hz			
Open			
Conv. thermal current	I_{th}	A	10
AC-15			
220 V 230 V 240 V	I_e	A	4
380 V 400 V 415 V	I_e	A	2
500 V	I_e	A	1.5
DC current			

DC-13 L/R - 15 ms				
Contacts in series:		A		
1	24 V	A	2.5	
2	60 V	A	2.5	
3	110 V	A	1.5	
3	220 V	A	0.5	
Control circuit reliability (at $U_e = 24$ V DC, $U_{min} = 17$ V, $I_{min} = 5.4$ mA)	Failure rate	λ	$<10^{-8}$, < one failure at 100 million operations	
Component lifespan at $U_e = 240$ V				
AC-15	Operations	$\times 10^6$	0.2	
DC				
Footnote				Switch-on and switch-off conditions based on DC-13, time constant as specified
L/R = 50 ms: 2 contacts in series at $I_e = 0.5$ A	Operations	$\times 10^6$	0.15	
Short-circuit rating without welding				
Maximum overcurrent protective device				
Short-circuit protection only				PKZM0-4
Short-circuit protection maximum fuse				
500 V		A gG/gL	6	
500 V		A fast	10	
Current heat loss at I_{th}				
Per contact		W	0.2	

Design verification as per IEC/EN 61439

Technical data for design verification				
Rated operational current for specified heat dissipation	I_n	A	4	
Heat dissipation per pole, current-dependent	P_{vid}	W	0.24	
Equipment heat dissipation, current-dependent	P_{vid}	W	0	
Static heat dissipation, non-current-dependent	P_{vs}	W	0	
Heat dissipation capacity	P_{diss}	W	0	
Operating ambient temperature min.		°C	-25	
Operating ambient temperature max.		°C	50	
IEC/EN 61439 design verification				
10.2 Strength of materials and parts				
10.2.2 Corrosion resistance				
				Meets the product standard's requirements.
10.2.3.1 Verification of thermal stability of enclosures				
				Meets the product standard's requirements.
10.2.3.2 Verification of resistance of insulating materials to normal heat				
				Meets the product standard's requirements.
10.2.3.3 Verification of resistance of insulating materials to abnormal heat and fire due to internal electric effects				
				Meets the product standard's requirements.
10.2.4 Resistance to ultra-violet (UV) radiation				
				Meets the product standard's requirements.
10.2.5 Lifting				
				Does not apply, since the entire switchgear needs to be evaluated.
10.2.6 Mechanical impact				
				Does not apply, since the entire switchgear needs to be evaluated.
10.2.7 Inscriptions				
				Meets the product standard's requirements.
10.3 Degree of protection of ASSEMBLIES				
				Does not apply, since the entire switchgear needs to be evaluated.
10.4 Clearances and creepage distances				
				Meets the product standard's requirements.
10.5 Protection against electric shock				
				Does not apply, since the entire switchgear needs to be evaluated.
10.6 Incorporation of switching devices and components				
				Does not apply, since the entire switchgear needs to be evaluated.
10.7 Internal electrical circuits and connections				
				Is the panel builder's responsibility.
10.8 Connections for external conductors				
				Is the panel builder's responsibility.
10.9 Insulation properties				
10.9.2 Power-frequency electric strength				
				Is the panel builder's responsibility.
10.9.3 Impulse withstand voltage				
				Is the panel builder's responsibility.
10.9.4 Testing of enclosures made of insulating material				
				Is the panel builder's responsibility.
10.10 Temperature rise				
				The panel builder is responsible for the temperature rise calculation. Eaton will provide heat dissipation data for the devices.
10.11 Short-circuit rating				
				Is the panel builder's responsibility. The specifications for the switchgear must be observed.

10.12 Electromagnetic compatibility		Is the panel builder's responsibility. The specifications for the switchgear must be observed.
10.13 Mechanical function		The device meets the requirements, provided the information in the instruction leaflet (IL) is observed.

Technical data ETIM 6.0

Low-voltage industrial components (EG000017) / Auxiliary contact block (EC000041)

Electric engineering, automation, process control engineering / Low-voltage switch technology / Component for low-voltage switching technology / Auxiliary switch block (ecI@ss8.1-27-37-13-02 [AKN342010])

Number of contacts as change-over contact		0
Number of contacts as normally open contact		1
Number of contacts as normally closed contact		3
Rated operation current I_e at AC-15, 230 V	A	4
Type of electric connection		Spring clamp connection
Model		Top mounting
Mounting method		Front fastening

Approvals

Product Standards		IEC/EN 60947-4-1; UL 508; CSA-C22.2 No. 14-05; CE marking
UL File No.		E29184
UL Category Control No.		NKCR
CSA File No.		012528
CSA Class No.		3211-03
North America Certification		UL listed, CSA certified

Characteristics

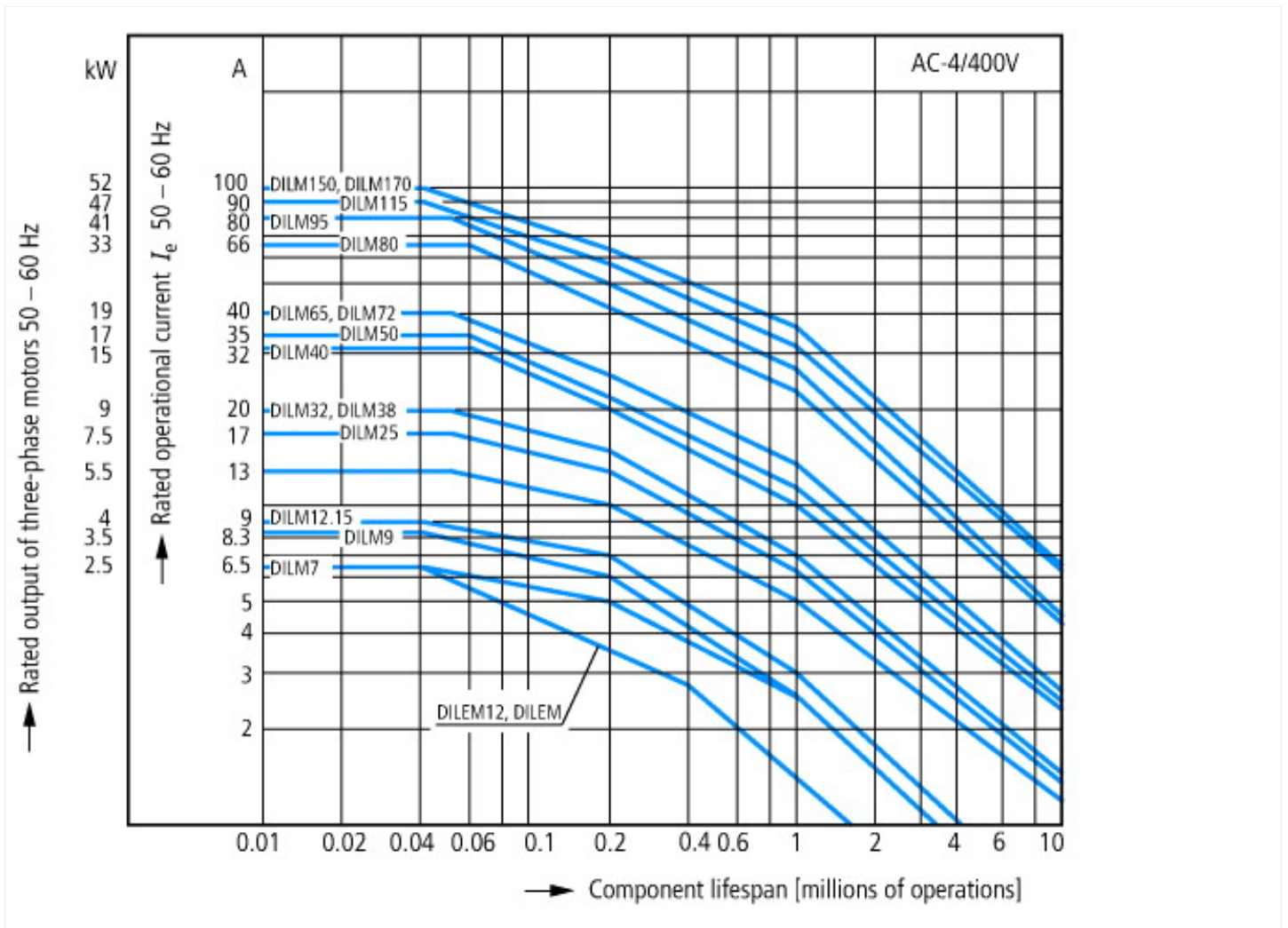

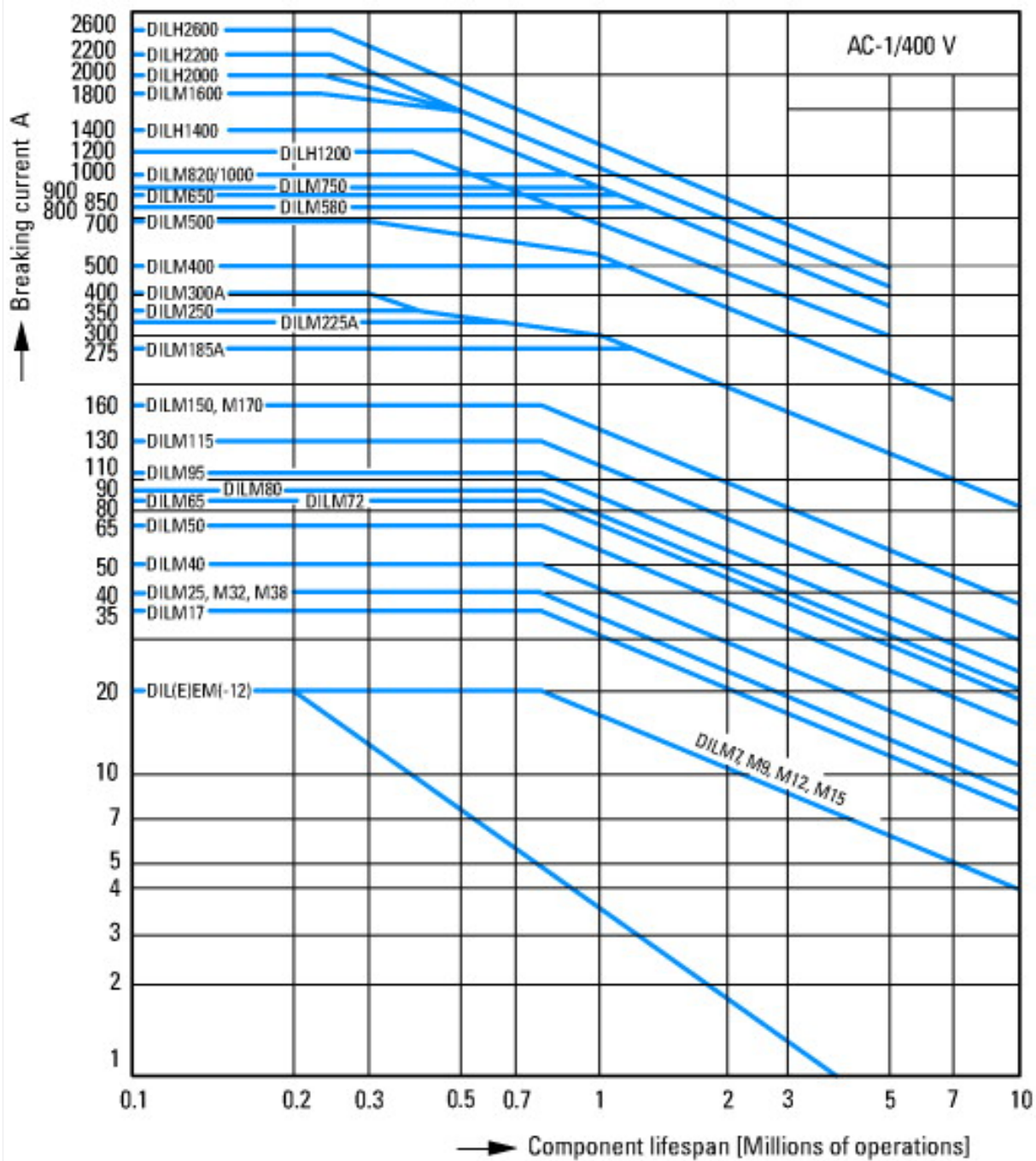

Switching duty for non-motor loads, 3-pole, 4-pole
 Operating characteristics
 Non-inductive or slightly inductive loads
 Electrical characteristics
 Make: 1 x rated current
 Break: 1 x rated current
 Utilization category
 100 % AC-1
 Typical applications
 Electric heat

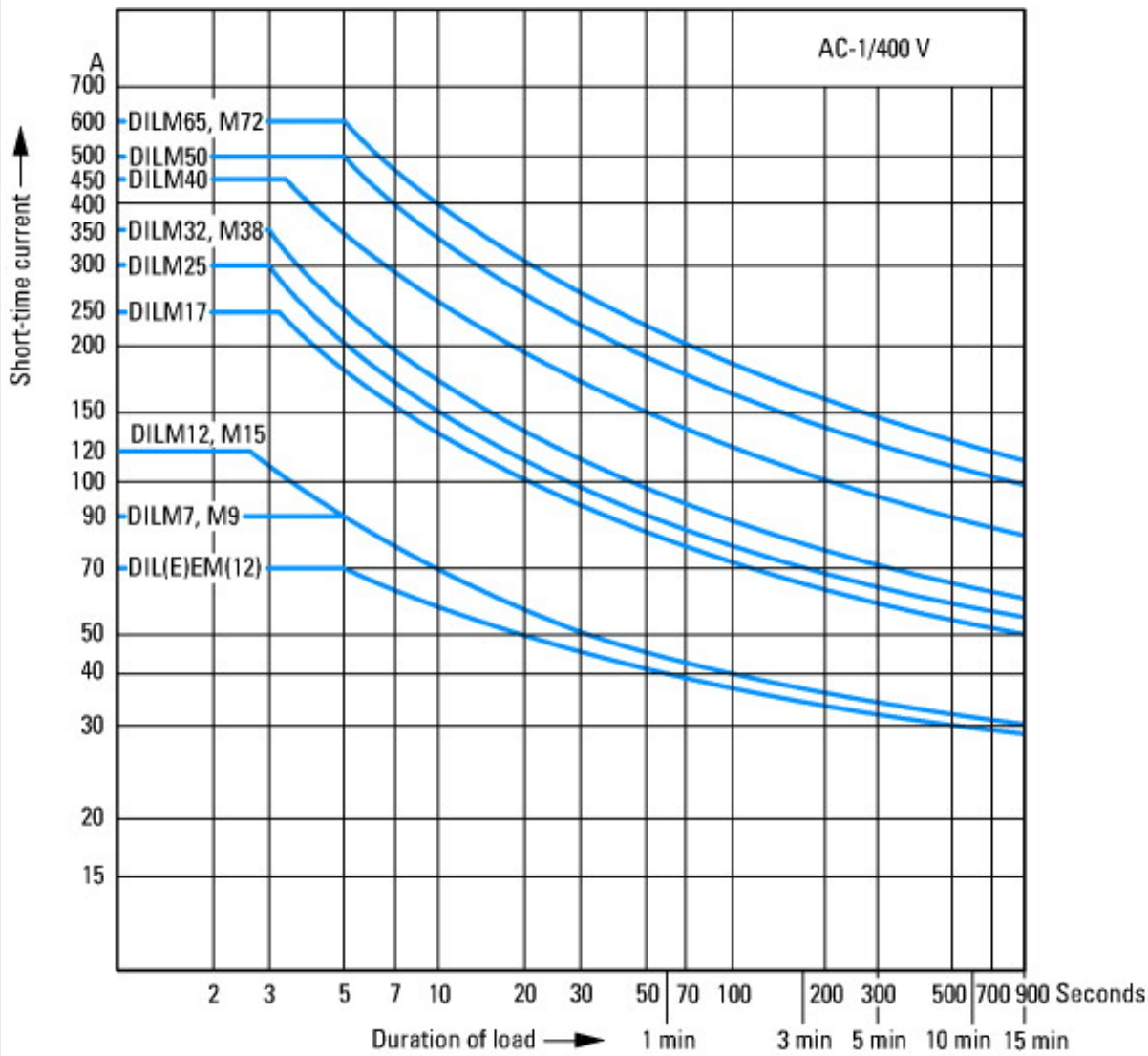

Short-time loading, 3-pole
Time interval between two loading cycles: 15 minutes

Dimensions

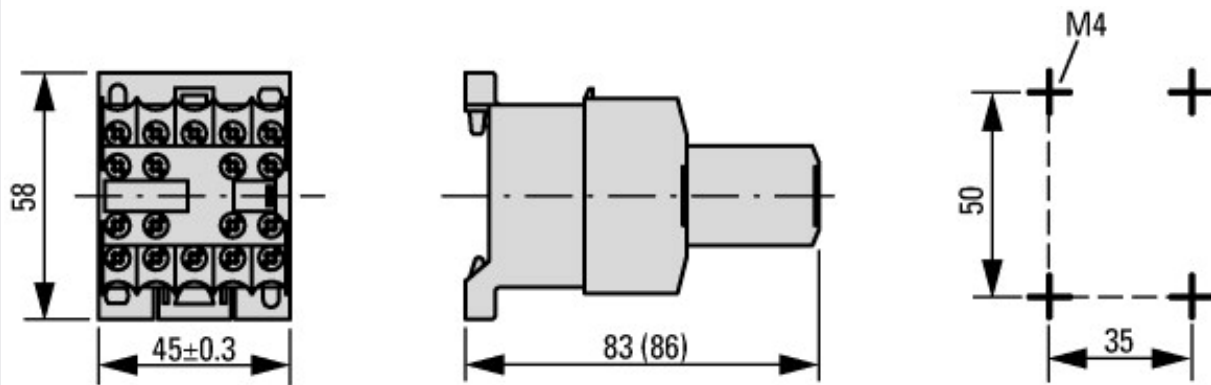

83 mm: DILE... + ...DILE(M)
86 mm: DILE...-C... + ...DILE(M)

Additional product information (links)

IL03407009Z (AWA2100-0882) Mini contactor relay

IL03407009Z (AWA2100-0882) Mini contactor relay

ftp://ftp.moeller.net/DOCUMENTATION/AWA_INSTRUCTIONS/IL03407009Z2016_03.pdf

UL/CSA: Approved rating data

<http://de.ecat.moeller.net/flip-cat/?edition=HPLTE&startpage=5.84>