

Wall fixing bracket

Part no. **+W-MCS**
 Article no. **001631**
 Catalog No. **-**

Delivery program

Product range		Accessories
Basic function		Wall fixing bracket
		Article no. for ordering with basic unit
For use with		MCS, MCSN

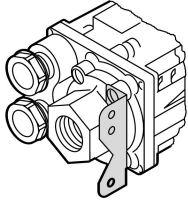

Notes

Wall mounting bracket can be rotated to right or left by 90°

Design verification as per IEC/EN 61439

Technical data for design verification		
Operating ambient temperature min.	°C	-25
Operating ambient temperature max.	°C	70

Technical data ETIM 6.0

Low-voltage industrial components (EG000017) / Accessories for low-voltage switch technology (EC002498)		
Electric engineering, automation, process control engineering / Low-voltage switch technology / Low-voltage switch technology (accessories) / Component for low-voltage switch technology (accessories) (ecl@ss8.1-27-37-92-01 [AKN570010])		
Type of accessory		Wall mount

Approvals

Product Standards		CSA-CC22.2 No. 14
CSA File No.		12528
CSA Class No.		3211-06
North America Certification		CSA certified

Dimensions

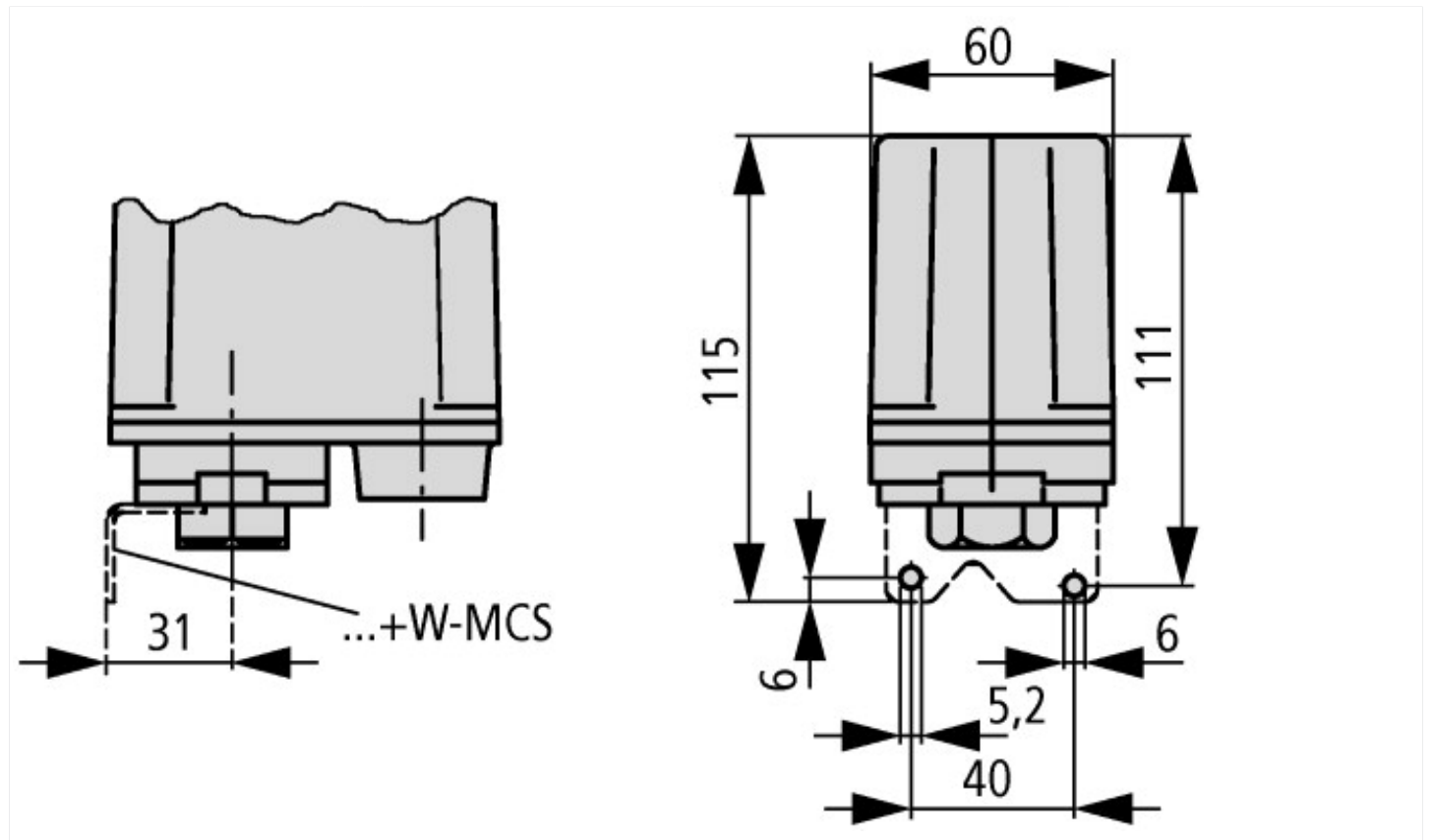

Additional product information (links)

IL05212001Z (AWA1320-0132) Pressure switch

IL05212001Z (AWA1320-0132) Pressure switch ftp://ftp.moeller.net/DOCUMENTATION/AWA_INSTRUCTIONS/IL05212001Z2016_02.pdf