







Connection, on rear, bottom 3p



Powering Business Worldwide™

Part no. **+NZM2-XKRU**
Article no. **266764**

Delivery program

Number of conductors			3 pole
Accessories			Connection on rear
Rated current	I_n	A	Cu 300, Al 250
For use with			NZM2, PN2, N2
Mounting position			Fitted at the bottom
Terminal capacities			
Type of conductor			
Cu/Al cable			Copper cable lugs Aluminium cable lug
Terminal capacities			
flexible		mm ²	1 x 10 - 185 2 x 4 - 70 1 x 10 - 50 2 x 10 - 50
Terminal capacities			
Cu strip (number of segments x width x segment thickness)		mm	 2 x 16 x 0.8  6 x 24 x 0.5
Copper busbar width x thickness	Breite	mm	 16 x 5  24 x 8
Notes			
Type suffix and type contain parts for a circuit-breaker side at top or bottom for 3 or 4-pole circuit-breakers.			
O = for fitting at the top			
U = for fitting at the bottom			

Design verification as per IEC/EN 61439

IEC/EN 61439 design verification			
10.2 Strength of materials and parts			
10.2.2 Corrosion resistance			Meets the product standard's requirements.
10.2.3.1 Verification of thermal stability of enclosures			Meets the product standard's requirements.
10.2.3.2 Verification of resistance of insulating materials to normal heat			Meets the product standard's requirements.
10.2.3.3 Verification of resistance of insulating materials to abnormal heat and fire due to internal electric effects			Meets the product standard's requirements.
10.2.4 Resistance to ultra-violet (UV) radiation			Meets the product standard's requirements.
10.2.5 Lifting			Does not apply, since the entire switchgear needs to be evaluated.
10.2.6 Mechanical impact			Does not apply, since the entire switchgear needs to be evaluated.
10.2.7 Inscriptions			Meets the product standard's requirements.
10.3 Degree of protection of ASSEMBLIES			Does not apply, since the entire switchgear needs to be evaluated.
10.4 Clearances and creepage distances			Meets the product standard's requirements.
10.5 Protection against electric shock			Does not apply, since the entire switchgear needs to be evaluated.
10.6 Incorporation of switching devices and components			Does not apply, since the entire switchgear needs to be evaluated.
10.7 Internal electrical circuits and connections			Is the panel builder's responsibility.
10.8 Connections for external conductors			Is the panel builder's responsibility.
10.9 Insulation properties			
10.9.2 Power-frequency electric strength			Is the panel builder's responsibility.
10.9.3 Impulse withstand voltage			Is the panel builder's responsibility.
10.9.4 Testing of enclosures made of insulating material			Is the panel builder's responsibility.
10.10 Temperature rise			The panel builder is responsible for the temperature rise calculation. Eaton will provide heat dissipation data for the devices.
10.11 Short-circuit rating			Is the panel builder's responsibility. The specifications for the switchgear must be observed.

10.12 Electromagnetic compatibility		Is the panel builder's responsibility. The specifications for the switchgear must be observed.
10.13 Mechanical function		The device meets the requirements, provided the information in the instruction leaflet (IL) is observed.

Technical data ETIM 6.0

Low-voltage industrial components (EG000017) / Wiring set for power circuit breaker (EC002050)

Electric engineering, automation, process control engineering / Low-voltage switch technology / Circuit breaker (LV < 1 kV) / Wiring set for circuit breaker (ecl@ss8.1-27-37-04-24 [ACN957008])

Suitable for number of poles

3

Model

-

Dimensions

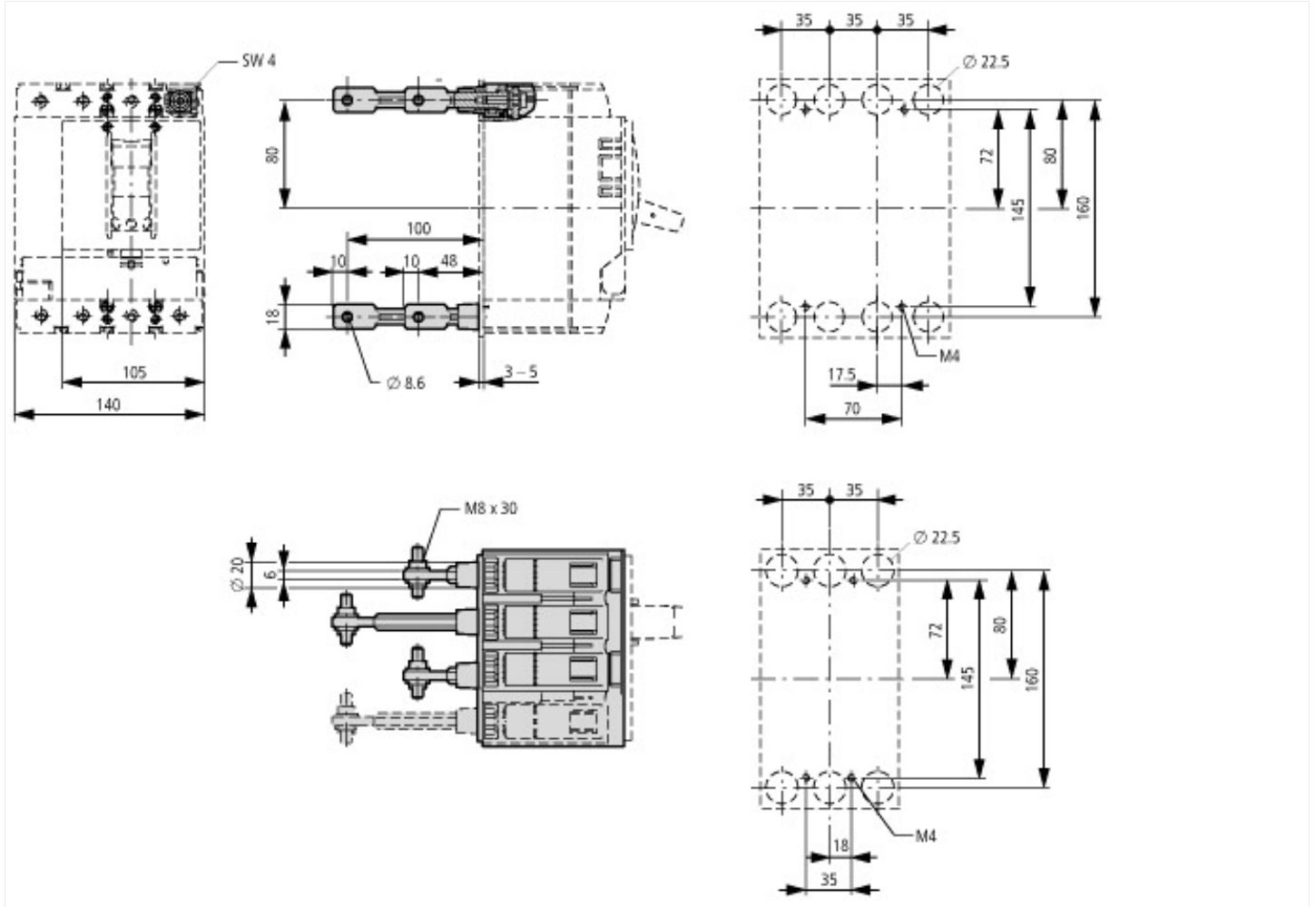

Additional product information (links)

IL01219047Z (AWA1230-2043) Rear connection

IL01219047Z (AWA1230-2043) Rear connection ftp://ftp.moeller.net/DOCUMENTATION/AWA_INSTRUCTIONS/IL01219047Z2011_02.pdf