



Mounting adapter for installing on the motor side

Part no. DX-EMC-MNT-1M
Article no. 172926
Catalog No. DX-EMC-MNT-1M

Delivery program

Part group reference (e.g. DIL)			DC1
Subrange			mounting adapter
Basic function			For installing the connection cables on the motor side
Description			Size FS1
For use with			DC1
Information about equipment supplied			With gland plates

Technical data ETIM 6.0

Low-voltage industrial components (EG000017) / Accessories for frequency controller (EC002025)			
Electric engineering, automation, process control engineering / Electrical drive / Electrical drive (accessories) / Frequency controller (accessories) (ec@ss8.1-27-02-92-01 [ACN127008])			
Type of accessory			Mounting set

Dimensions

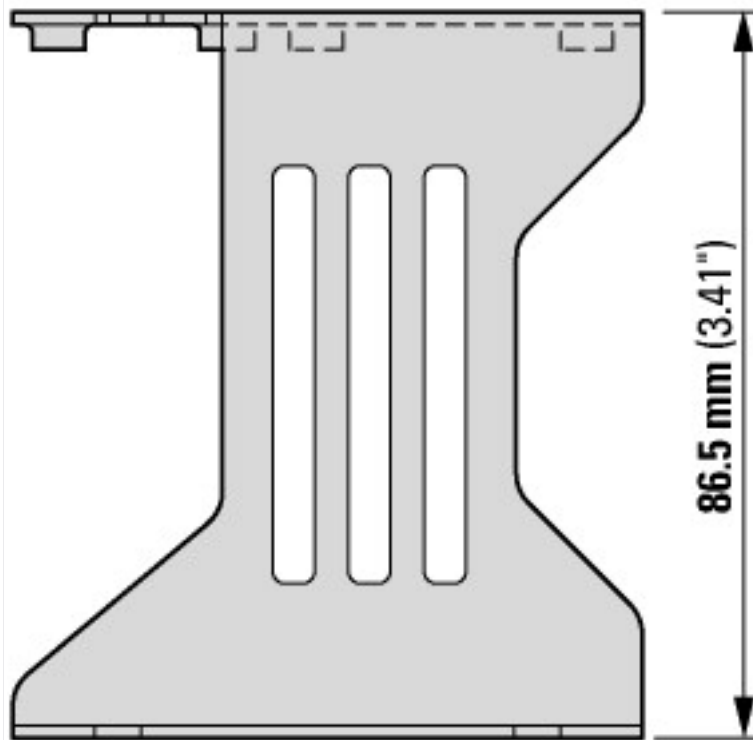
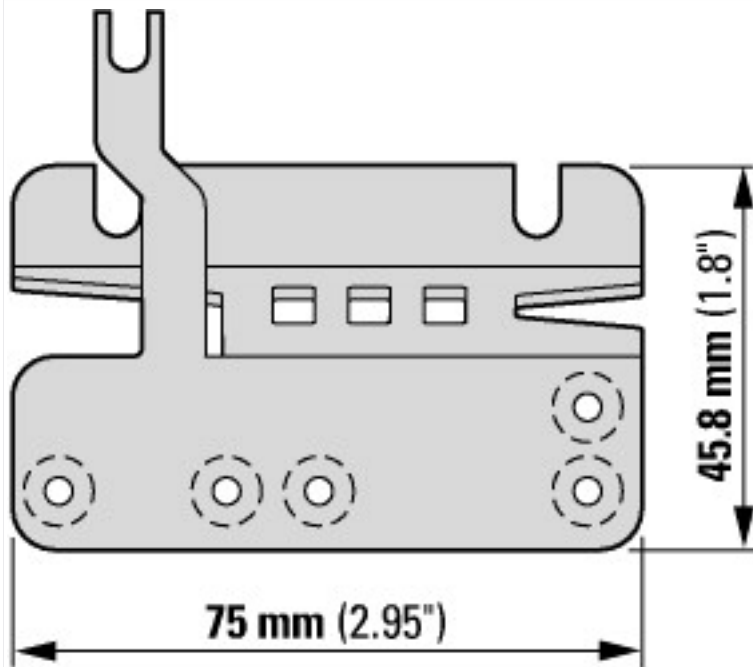

Additional product information (links)

CA04020001Z-DE Sortimentskatalog: Antriebstechnik effizient gestalten, Motoren starten und steuern

http://www.eaton.eu/DE/ecm/groups/public/@pub/@europe/@electrical/documents/content/pct_1095238_de.pdf