





DC switch-disconnector, 2 pole, 200 A, with grey knob, rear mounting

Part no. DDC-200/2
Article no. 6098936

Delivery program

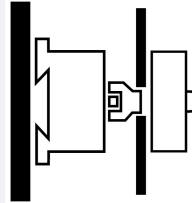
Product range			DC switch-disconnector Main switch maintenance switch
Part group reference			DDC with grey knob
Information about equipment supplied			auxiliary contact fitted by user.
Number of poles			2 pole
Auxiliary contacts			
		N/O	2
		N/C	2
Degree of Protection			IP20
Design			rear mounting
			
Rated uninterrupted current	I_u	A	200

Technical data

General

Standards			IEC/EN 60947, VDE 0660, IEC/EN 60204, Switch-disconnector according to IEC/EN 60947-3
Certifications			CE, RoHs
Ambient temperature			
Storage	θ	°C	-40 - +80
Overvoltage category/pollution degree			III/3
Rated impulse withstand voltage	U_{imp}	kV	8
Rated insulation voltage	U_i	V	1200
Mounting position			As required
Protection against direct contact when actuated from front (EN 50274)			Finger and back-of-hand proof

Contacts

Mechanical variables			
Number of poles			2 pole
Auxiliary contacts			
		N/O	2
		N/C	2
Electrical characteristics			
Rated uninterrupted current	I_u	A	200
Note on rated uninterrupted current I_u			Rated uninterrupted current I_u is specified for max. cross-section.
Rated short-time withstand current (1 s current)	I_{cw}	A_{rms}	4000
Note on rated short-time withstand current I_{cw}			Current for a time of 1 second
Rated short-circuit making capacity	I_{cm}	kA_{eff}	6

Switching capacity

Lifespan, mechanical	Operations	10000
----------------------	------------	-------

DC				
Utilization category DC21B				
Rated operational current switch				
480 V	I_e	A	200	
600 V	I_e	A	200	
1000 V	I_e	A	200	

Terminal capacities

Solid		mm^2	1 x 120	
Flat conductor connection with busbars		mm^2	1 x (30 x 3) 2 x (20 x 3)	
Terminal screw			M8	
Max. tightening torque		Nm	14	

Technical data ETIM 6.0

Low-voltage industrial components (EG000017) / Switch disconnecter (EC000216)				
Electric engineering, automation, process control engineering / Low-voltage switch technology / Off-load switch, circuit breaker, control switch / Switch disconnecter (ecl@ss8.1-27-37-14-03 [AKF060010])				
Version as main switch				Yes
Version as maintenance-/service switch				Yes
Version as safety switch				No
Version as emergency stop installation				No
Version as reversing switch				No
Max. rated operation voltage U_e AC		V	0	
Rated operating voltage		V	1000 - 1000	
Rated permanent current I_u		A	200	
Rated permanent current at AC-21, 400 V		A	0	
Rated operation power at AC-3, 400 V		kW	0	
Rated short-time withstand current I_{cw}		kA	4	
Rated operation power at AC-23, 400 V		kW	0	
Switching power at 400 V		kW	0	
Conditioned rated short-circuit current I_q		kA	0	
Number of poles			2	
Number of auxiliary contacts as normally closed contact			0	
Number of auxiliary contacts as normally open contact			0	
Number of auxiliary contacts as change-over contact			0	
Motor drive optional			No	
Motor drive integrated			No	
Voltage release optional			No	
Device construction			Built-in device fixed built-in technique	
Suitable for ground mounting			Yes	
Suitable for front mounting 4-hole			No	
Suitable for front mounting center			No	
Suitable for distribution board installation			No	
Suitable for intermediate mounting			No	
Colour control element			Grey	
Type of control element			Long turning handle	
Interlockable			Yes	
Type of electrical connection of main circuit			Screw connection	
Degree of protection (IP), front side			IP20	

Dimensions

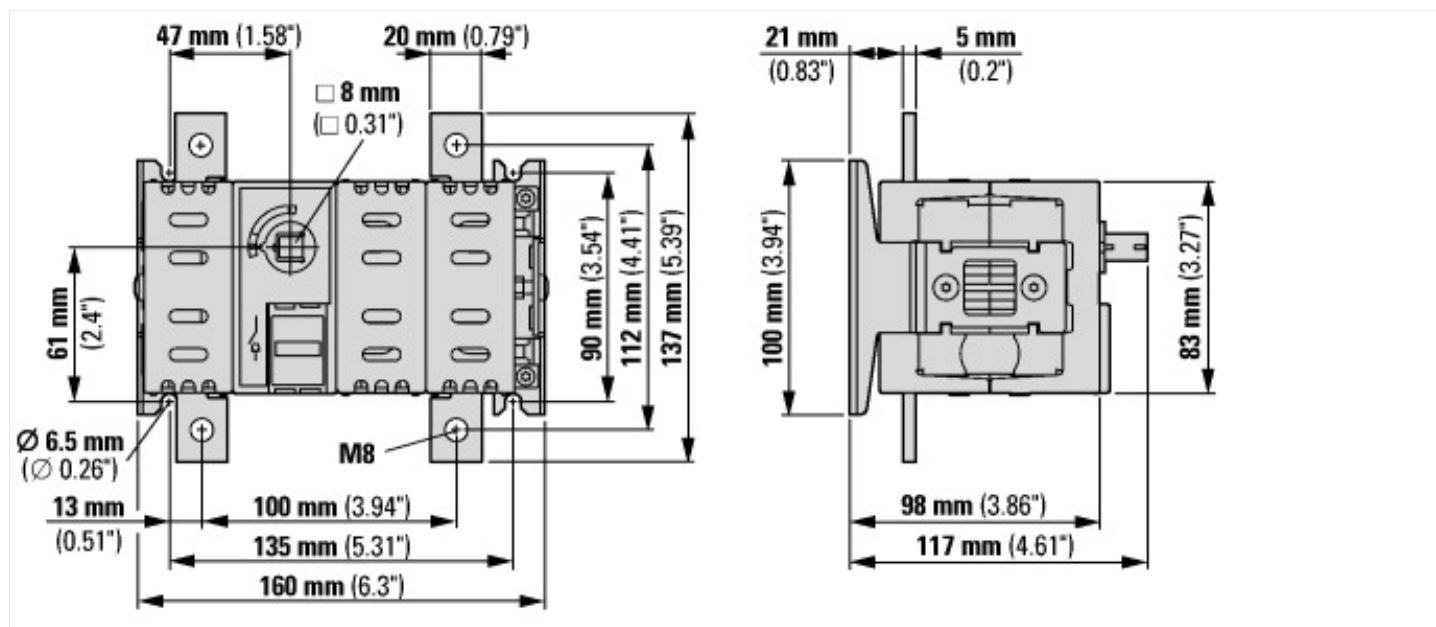

Additional product information (links)

IL008021ZU Switch disconnector DDC, DC-Switch (Box 1)

IL008021ZU Switch disconnector DDC, DC-Switch (Box 1)	ftp://ftp.moeller.net/DOCUMENTATION/AWA_INSTRUCTIONS/IL008022ZU2015_12.pdf
Technical overview cam switch, switch-disconnector	http://de.ecat.moeller.net/flip-cat/?edition=HPLTEv1&startpage=4.2
System overview cam switch T	http://de.ecat.moeller.net/flip-cat/?edition=HPLTEv1&startpage=4.4
System overview switch-disconnector P	http://de.ecat.moeller.net/flip-cat/?edition=HPLTEv1&startpage=4.6
Key to part numbers Cam switch	http://de.ecat.moeller.net/flip-cat/?edition=HPLTEv1&startpage=4.8
Key to part numbers Switch-disconnector	http://de.ecat.moeller.net/flip-cat/?edition=HPLTEv1&startpage=4.8
Switches for ATEX	http://www.coopercrouse-hinds.eu/en/products/25-ex-safety-and-main-current-switches.html